



LKD系列离心式空调风机技术手册 The LKD Series Centrifugal Fan



浙江莱恩克风机有限公司
ZHEJIANG LION KING VENTILATOR CO., LTD.



Megan Chan
General Sales Manager
Zhejiang Lion King Ventilator Co., Ltd.

☎ 008618167069821
✉ lionking@lkfan.com
🌐 <https://www.lkventilator.com/>
📍 Add.: No. 688, Yangsi Road, Zhang'an, Jiaojiang District, Taizhou City, Zhejiang Province, China

浙江莱恩克风机有限公司
ZHEJIANG LION KING VENTILATOR CO., LTD.



企业理念

Qualification Certificate

诚信立足，创新发展，共赢致远……

Based on Honesty, Innovation to Promote Development, Mutual Benefits Lead to Great Future

诚信是莱恩克公司的立身之本。莱恩克一贯奉行全方位的诚信理念，倡导企业管理层、员工诚信经营、诚信服务，倡导同社会、客户、合作伙伴和谐发展，为铸造百年企业打下扎实根基。

创新是莱恩克公司的活力之源。公司大力倡导创新精神，积极营造尊重劳动、尊重知识、尊重人才、尊重创造的良好氛围，在实践中不断推进体制、机制、科技、产品等创新活动，为社会提供更优质的产品和服务。

共赢是莱恩克公司的致远之道。公司通过诚信的态度，务实的作风，创新的思维，努力达成企业、员工、客户、合作伙伴、社会多方共赢，使得企业长远稳定发展。

Honesty is the foundation of LION KING. We consistently pursue good faith as our principle. We advocate our managers and employees operating honestly, and we advocate to develop with society, customers and partners in harmony to make our company to exist more than one hundred years.

Innovation is the source of vitality of LION KING. We advocate innovation, and actively create good atmosphere for innovation, such as respecting talents, respecting knowledge, respecting hardworking, respecting creation. And in practice, we continue to promote innovation of our system, mechanism, technologies and products.

Mutual benefits are the way to lead us to a great future. With honest attitude, pragmatic work style and innovative thinking, we'll try our best to achieve multi-win situation for our company, employees, customers, partners and the society, which will help us for a long-time sustainable development.

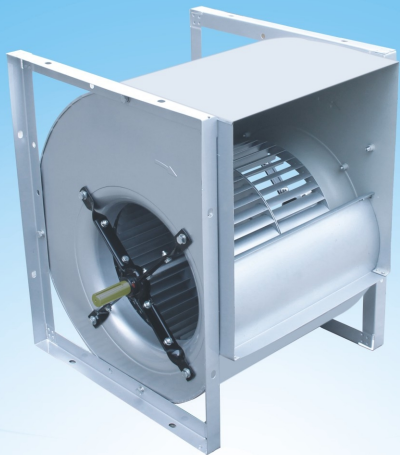

Contents 目录

LKD系列离心式空调风机产品说明	01
LKD Series Centrifugal Fan Instructions	
LKD系列离心式空调风机技术参数	09
LKD Series Centrifugal Fan Technical Parameters	



浙江莱恩克风机有限公司特此证明，此处所示LKD系列离心式空调风机获得了加盖AMCA印章的授权。所示额定值系根据AMCA出版物211和AMCA出版物311，所进行测试和程序确定，并符合AMCA认证额定值计划的要求。

Zhejiang Lion King Ventilator Co Ltd certifies that the LKD Centrifugal Fan series shown herein is licensed to bear the AMCA Seal. The ratings shown are based on tests and procedures performed in accordance with AMCA Publication 211 and AMCA Publication 311 and comply with the requirements of the AMCA Certified Ratings Program.



命名方式

Nomenclature

LKD系列风机命名方式由风机系列代号、叶轮名义直径、结构型式组成:

The model designations signify the nominal impeller outside diameters:

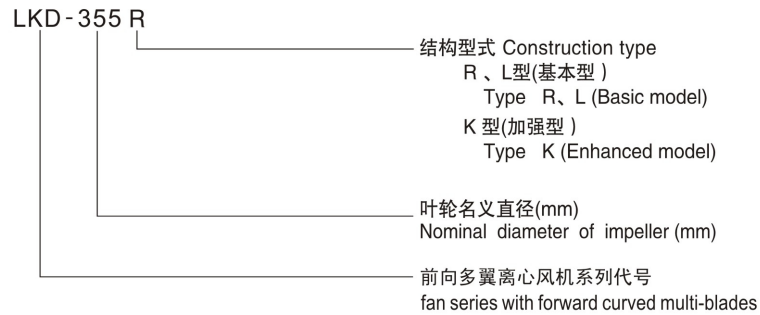

产品形式

Product Features

1. 旋向

LKD系列风机可分为左旋(LG)和右旋(RD)两种旋转方式,从风机皮带轮一端正视,叶轮顺时针旋转的称为右旋风机,逆时针旋转的称为左旋风机。皮带轮可左右调向,因此不受左右方向的限制。

LKD Series ventilator can be divided into two direction of rotations, left-hand rotation(LG) and right hand rotation (RD): Viewing from end of motor outlet line if the impeller rotates clockwise, it is called right hand ventilator, if the impeller rotates anti-clockwise, it is called left hand ventilator. The pulley can adjust its direction, left or right, therefore there is no limitation in directionality.

2. 出风口方向

LKD系列风机可按图1所示制成0°、90°、180°、270°四种出风方向。

2. Direction of Air Outlet

According to Fig 1, LKD Series ventilator can be made in four air-outlet directions: 0°, 90°, 180°, and 270°.



图1(Fig1)

3. 结构形式

LKD系列风机可按图2所示制成L型、LK、R型、RK型、L2型、R2型、K型、K2型。

3. Type of structure

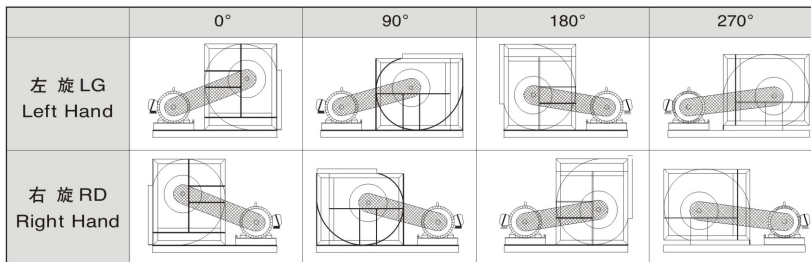
According to Fig2, LKD series ventilators can be divided into Category L.LK.R.RK Category L2.R2、Category L.K.K2



图2 (Fig2)

产品结构

Constructon of Product

LKD系列风机主要由机壳、叶轮、框架、轴、出口法兰(常规配置不带法兰)构成。

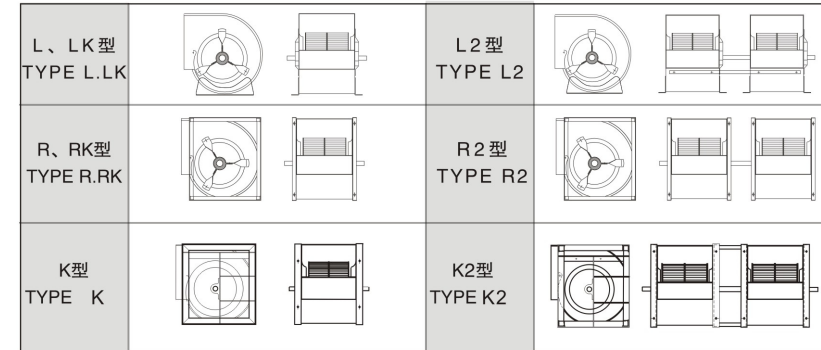
LKD series ventilators are mainly consisted of scroll, impeller, frame bearing, shaft and outlet flange (generally is not included)

1. 机壳

机壳采用热镀锌钢板制造,侧板具有符合空气动力学的外形,进风口整体拉伸成型,蜗板采用点焊或咬口的方式与侧板连成一体。

1). Scroll

The scroll is made of hot galvanizing steel sheet. Its side plate has an outline complying with aerodynamics. The scroll plate fixed to the side plates by means of "electric spot welding" or "seam locking"

2. 叶轮

前向多翼叶轮采用优质热镀锌钢板制成,叶片设计成符合空气动力的特定形状,使得效率最高、噪声最低。叶片用铆钉固定在中盘及端圈上,在最大功率连续运转时,叶轮将具备足够的刚度。后向叶轮采用优质冷轧钢板制成,按三元流理论设计的叶片焊接在经数控机床加工的中盘和端圈上,整体喷塑。叶轮出厂前按高于国家标准的内控动平衡等级全检合格。

2. Impeller

Forwards curved impeller is made of high grade hot galvanizing steel sheet and is designed to a special configuration according to aerodynamics to make the efficiency highest and the noise lowest. The impeller is fixed on the middle disk plate and on the end ring with riveting grippers. The impeller has enough rigidity during continuous rotation with maximum power. Backwards curved vial impellers are made of high grade cold-rolled sheet. The vane blades which are designed in three-dimensional theory are welded between middle tray and endmost. Before leaving factory, all impellers have passed all-round dynamic balance test according to the Company Standard which is higher level than National Standard.



3. 框架

R型风机框架采用热镀锌钢板剪切、折弯制成，TOX连接保证了所需的尺寸精度和应有的刚度；K型风机框架由角钢和扁钢焊接制成，表面喷漆，以保证足够的刚度和强度。

4. 轴承

LKD系列风机均采用优质滚珠轴承，并根据噪声最低来选择，该轴承设有加润滑油的孔，已预先加润滑油并自动对中；L、R型风机的轴承安装在轴承支架上，并设有防振垫圈；K型风机则采用带座向心球轴承；Z型风机采用重载荷的双列滚柱轴承的轴承箱结构。

5. 轴

风机轴采用特制钢经粗加工、调质处理及磨削加工制成，严格控制轴径尺寸公差及形位公差，每根轴均经过涂覆防锈处理。

6. 出风口法兰

法兰采用热镀锌钢板制成，法兰与蜗壳的连接采用TOX免焊工艺，外观精美，并具有足够的刚度与强度。

3. Frame

The frames for type R ventilators are made of galvanized steel angle iron bars. The cutting and bending of the frame parts, as well as the TOX connections, are formed with the use of molds to assure their high accuracy and the rigidity of the frames; The frames for type K ventilators are welded by angle steel and flat steel, and they are finished with polyestes coatings in order to assure sufficient rigidity and intensity.

4. Bearings

Ball bearings are used in all of the LKD Series ventilators. They are high quality bearings and they are selected to minimize the ventilator noise levels. The bearings are pre-lubricated, sealed, and self-centering. For type L ventilators, the bearings are mounted using vibration resistant washers. For type R ventilators, self-aligning pillow block ball bearings are used, Type K ventilators bearings are supplied with lubrication fittings. The ventilators of type Z use the bearing housing which with heavy load double-row roller bearing.

5. Shaft

The shafts are made of Special steel bars. The shafts are rough machined and then stress relieved before final machining. The shaft diameters are machined to very accurate tolerance levels and they are fully checked to assure precision fits They are coated after assembly in order to provide corrosion resistance.

6. Outlet Flange

The outlet flange is made of galvanized steel. The connections of the flange components to each other and to the scroll are made using a TOX non-welding process. This maintains a good flange appearance while also providing sufficient strength and rigidity. The outlet flange dimensions are provided in Figure 3.

上述式中

- 流量 Q_0 (m³/h)、全压 P_0 (Pa)、转速 n (r/min)、内功率 N_{in0} (Kw)由性能曲线图上查得。
- 右上角加符号“*”的则为用户实际使用气体进气状态下所需的性能参数。
- 上式中略去了相对湿度的差别。

2. 性能曲线图上的功率 N_{in0} 是指风机的内功率。

- 风机轴功率： $N_s = N_{in0} / \eta_m$

$$\text{式中：} N_s - \text{风机轴功率}$$

$$\eta_m - \text{风机机械效率}$$

风机机械效率的取值方法可参照表1。

风机传动方式Way of ventilator driving	η_m
电机直联传动electric motor directly driven	1
联轴器直联传动Coupling directly driven	0.98
三角皮带传动V-belt driven	0.95

表1 (Table1)

(2) 配套电机的功率： $N = N_s \cdot K$

式中： N -配套电机的功率

K -电机容量安全系数

电机容量安全系数的取值方法可参照表2。

电机功率Power of electric motor(Kw)	K值Value k
$\leq 2.2Kw$	1.2
$\leq 7.5Kw$	1.15
$\geq 11Kw$	1.1

表2 (Table2)

where:

- Volume Q_0 (m³/h), total pressure P_0 (Pa), speed n (r/min) can be obtained from Performance chart.

- Asterisk (*) on the upper right corner denotes the performance parameter needed by the customers in practical gas inlet conditions.

- The difference in relative humidity is omitted from the above-mentioned formulas.

2. The power (N_{in0}) on the performance chart the internal power of the ventilator.

- Shaft power of ventilator: $N_s = N_{in0} / \eta_m$

where: N_s —Shaft power of ventilator

η_m —Mechanical efficiency of ventilator

The value of mechanical efficiency of ventilator can be obtained from Table 1.

(2) The rated power of the drive motor equals the total required shaft input power multiplied by the safety factor:

$N = N_s \cdot K$

where: N = rated power of drive motor

K = required safety factor

The required safety factor is provided in Table 2.

风机性能

Performance of Ventilator

1. 该样本中风机性能均指在标准状态下的性能，即风机进气状态为：

进气压力 $P_a = 101.325KPa$
 进气温度 $t = 20\text{ }^\circ C$
 进气气体密度 $\rho = 1.2Kg/m^3$

若用户实际使用的气体进气状态或使用的风机转速改变时则可按下列关系式换算：

$$\frac{Q_0'}{Q_0} = \frac{n'}{n}$$

$$\frac{P_0'}{P_0} = \frac{n'^2}{n^2} \cdot \frac{\rho'}{\rho} \quad \frac{P_0'}{P_0} = \frac{n'^2}{n^2} \cdot \frac{P_a'}{P_a} \cdot \frac{273+t}{273+t'}$$

$$\frac{N_{in0}'}{N_{in0}} = \frac{n'^3}{n^3} \cdot \frac{\rho'}{\rho} \quad \frac{N_{in0}'}{N_{in0}} = \frac{n'^3}{n^3} \cdot \frac{P_a'}{P_a} \cdot \frac{273+t}{273+t'}$$

1. The ventilator performance in this catalogue denotes the performance in standard conditions. It denotes air inlet conditions of ventilator as follows:

Air inlet pressure $P_a = 101.325KPa$
 Air temperature $t = 20\text{ }^\circ C$
 Inlet gas density $\rho = 1.2Kg/m^3$

If the practical air inlet conditions of customer or the speed of the operating ventilator changes, the conversion can be carried out according to the following expression:

$$\frac{Q_0'}{Q_0} = \frac{n'}{n}$$

$$\frac{P_0'}{P_0} = \frac{n'^2}{n^2} \cdot \frac{\rho'}{\rho} \quad \frac{P_0'}{P_0} = \frac{n'^2}{n^2} \cdot \frac{P_a'}{P_a} \cdot \frac{273+t}{273+t'}$$

$$\frac{N_{in0}'}{N_{in0}} = \frac{n'^3}{n^3} \cdot \frac{\rho'}{\rho} \quad \frac{N_{in0}'}{N_{in0}} = \frac{n'^3}{n^3} \cdot \frac{P_a'}{P_a} \cdot \frac{273+t}{273+t'}$$

3. 噪声：噪声等级显示在每个性能表上。

L_{wiA} 为总声功率级的A计权声级。计算所得的总声功率级用表3中倍频谱的A计权衰减值换算至A声功率级。

3. Noise: The noise levels shown on each performance chart, L_{wiA} , refer to the overall sound power "A-Weighted" levels. The computed sound power levels were converted into A-Weighted levels using adjustments to the octave band spectrum as follows:

中心频率 Center Frequency Hz	63	125	250	500	1000	2000	4000	8000
调整为A-Weighted Adjustment dB(A)	-25.5	-12.5	-8.5	-3	0	+1	+1	-1

表3 (Table3)

总声压级 L_{piA} 能利用总声能等级按如下公式计算：

无边状态： $L_{piA} = L_{wiA} - (20 \log_{10} d) - 11$

室内状态： $L_{piA} = L_{wiA} - (20 \log_{10} d) - 7$

式中： d = 离风机距离(m)

The overall sound pressure levels, L_{piA} , can be computed from the overall sound power levels as follows:

Free Field Conditions: $L_{piA} = L_{wiA} - (20 \log_{10} d) - 11$

Room Conditions: $L_{piA} = L_{wiA} - (20 \log_{10} d) - 7$

Where: d = distance from fan in meters.



4. L2型、R2型、K2型双联风机性能与L型、R型、K型风机曲线上所示性能比较，在压力相同情况下，双联风机性能如下：

风量 x 2
转速 x 1.05
内功率 x 2.15
噪声 +3

双联风机的性能未获AMCA International 授权。

4. Comparing the performance of the twin ventilator of Category L2 Category R2 and Category K2 with the performance of Category L Category R and K in the chart in the same condition of pressure, the twin ventilators' performance is as the following.

Volume x 2
Speed x 1.05
Inner Power x 2.15
Noise +3

Performance of twin ventilators are not licensed by AMCA International.

皮带转动安装

1. 拆除风机轴端的保护并检查有无缺口和毛刺；
2. 检查风机和电机轴之间的平行度；
3. 中心距控制在 $0.7(d1+d2) < a < 2(d1+d2)$ ，前向风机皮带速度应控制在10~15m/s；后向风机皮带速度应控制在25~35m/s；
4. 将皮带轮套在轴上滑进去，不要敲击，以免损伤轴承；
5. 用一根直尺把风机和电机上的带轮对齐并紧固；
6. 把皮带套进皮带轮，不要撬、挤压，以免损伤皮带；
7. 调整张紧度直至皮带看起来松紧适度，风机运行几分钟后，再调整皮带至合适的张紧度；
8. 关掉风机，移动电机座以调整张紧度，当风机工作时，皮带紧的一边应是两个皮带轮连成的一直线，松的一边有轻微弧形。

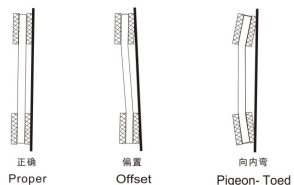

V-BELT DRIVE INSTALLATION

1. Remove the protective coating from the ends of the fan shaft and assure that the shaft ends are free of nicks and burrs.
2. Check fan and motor shafts for parallel and angular alignment.
3. The center distance must be controlled as $0.7(d1+d2) < 2(d1+d2)$; the belt speed of forward fan should be more than 10m/s, but less than 15m/s, ($10 < v < 15$ m/s); the belt speed of backward fan should be more than 25m/s, but less than 35m/s, ($25 < v < 35$ m/s);
4. Slide sheaves on to the shafts—do not drive the sheaves on to the shafts as this may result in bearing damage.
5. Align fan and motor sheaves with a straight-edge or string, and tighten.
6. Place belts over the sheaves with carefull, otherwise the belts will be damaged.
7. Adjust the belt tension until the belts appear snug. Run the unit for a few minutes and allow the belts to set properly.
8. Switch off the fan, adjust the belt tension by moving the motor base. When in operation, the tight side of the belts should be in a straight line from sheave to sheave and there should be a slight bow on the slack side.



皮带松紧度

合适的皮带松紧度对使用寿命来说很重要太紧会给皮带和轴承带来额外的负载，降低它们的使用寿命，太松会出现皮带打滑现象而产生热能并降低使用寿命。

皮带松紧度量具可用来判断皮带是否松紧合适。量具本身带有一个尺表，根据皮带轮中心距和皮带横截面确定皮带张紧力的大小，如图4和表3。

如没有皮带张紧度量具，应调节皮带松紧至风机启动时皮带不发出尖叫声为止，如发出短促的叫声是允许的。

拉紧皮带后、开动风机之前，重新检查皮带的对齐情况，如有必要则重新调整对齐。新皮带在开始使用时可能有点拉伸，则应在运行几天后重新检查皮带张紧度。

与中心距有关的皮带张紧度指示
Belt tension indicator applied to mid centre distance.



图4 (Fig4)

Belt tension

A proper level of belt tension is required in order to obtain a satisfactory belt life. If the belt tension level is too high, then excessive loads will be imposed on the belts and the bearings, and this will reduce the lives of both of these components. If the belt tension level is too low, then the belt will slip. Belt slippage generates a large amount of heat, and this heat will drastically reduce the life of a belt.

Belt-tensioning gauges can be used to determine whether the belts are tensioned properly. A chart is normally supplied with the gauge which indicates the ranges of forces required to deflect the belts by a given amount to obtain the proper belt tension level. The required forces are based on the center distance of the sheaves and the belt cross-section, the belts are properly tensioned when the forces required to deflect the belt are within the specified range, see Fig4 and Table3.

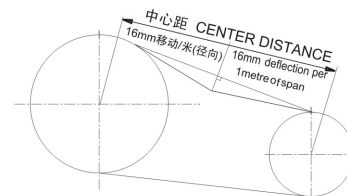
If a belt-tensioning gauge is not available, then the belt should be tightened just enough so that the belt does not squeal when the ventilator is started. A very short period of noise during the starting of a ventilator is allowable, but a squeal lasting several seconds or longer is not acceptable. After tensioning the belts and before starting the ventilator, check to make sure that the sheaves are properly aligned.

Realign the sheaves if necessary, note that new belts may stretch a little during initial use, so the belt tension level should be checked after a few days of operation.

皮带截面 Belt Section	使皮带向下移动16mm经向距离1米所需的力 Force required to deflect belt 16mm per metre of span		
	张紧力 (小皮带轮直径) Serial Pulley Diameter (mm)	牛顿	千克力 Kilogram force (kgf)
SPZ	56-95	13-20	1.3-2.0
	100-140	20-25	2.0-2.5
SPA	80-132	25-35	2.5-3.6
	140-200	35-45	3.6-4.6
SPB	112-224	45-65	4.6-6.6
	236-315	65-85	6.6-8.7
SPC	224-335	85-115	8.7-11.7
	375-560	115-150	11.7-15.3
A	80-140	10-15	1.1-1.5
B	125-200	20-30	2.0-3.1

表3 (Table3)

轴承润滑

风机使用带座轴承，可通过加油嘴注入润滑油。润滑油有效期取决于油脂类型、轴承的转速和工作温度。判断是否加油的最好办法是当加新油时观察清除下来的旧油脂，如果清除下来的油脂看起来还是新的，可延长换油脂的间隔，如果清除下来的油脂比新的黑得多表明油脂已氧化，应缩短换油脂的间隔。

Bearing Lubrication

The ventilator bearings are filled with lubricant when they come from the factory, so the bearings do not require any additional grease to be supplied before starting the ventilator.

The ventilator that are equipped with pillow block bearings are provided with lubrication fittings, and these fittings allow for additional lubrication to be supplied to the bearings at regular intervals. The allowable period of time between lubrication of these bearings depends upon the operating speeds and temperatures of the bearing as well as on the type of grease used. The best way to determine the required frequency of lubrication is to inspect the condition of the grease that is discharged from the seals when new grease is added. If the discharged grease looks similar to the new grease, then a longer period of time between lubrications is possible. If the discharged grease is much darker than the new grease, then this indicates that the grease is being oxidized and more frequent lubrications of the bearings are required.



说明

Instructions

- 1). 订货时须注明风机型号、转速、风量、风压、风压、出风口方向和旋转方向。若需配套皮带、皮带轮、电机、安装底座等配件及其它特殊要求可在订货时提出。
- 2). 在安装前应对风机各部件进行检查，对叶轮、主轴和轴承等主要机件应重点细致检查，若有损伤应修复后再安装使用。
- 3). 检查机壳和其它壳体内部，不应有掉入、遗留的工具和杂物。
- 4). 风机正式运转前，需检查电机的转向是否符合风机转向的要求。
- 5). 风管与出风口之间应采用软连接，接头不得拉紧。
- 6). 风机安装后用手或杠杆拨动叶轮，检查是否过紧或碰撞现象，确认无这些现象时方可进行试转。
- 7). 风机配用电动机功率是指在特定工况下，风机内功率加上机械损失与电机容量安全系数而言，并非出风口全敞开时所需的功率。为防止电机超功率运转而烧毁，严禁风机出风口或进风口不接管路或未加外界任何阻力进行空运转。
- 8). 风机在无污染腐蚀性气体、不含酸(碱)性和尘粒物质小于150mg/m³的气体、温度小于85°C大于-20°C的气体环境下使用，风机在运输装卸过程中应小心轻放，防止碰撞挤压。

- 1). During ordering it is necessary to state the type of ventilator, speed, air volume, air pressure, direction of air outlet, rotating direction, type of electric motor and its specifications.
- 2). Prior to installation, the ventilator should be carefully inspected. Special care should be taken in checking the shaft, impeller and bearings. If there is an indication of any damage, then the damaged parts should be repaired or replaced before the ventilator is installed or operated.
- 3). The inside of the scroll and casing need to be checked to make sure that there are no foreign objects contained therein, such as tools or loose parts.
- 4). The rotational directions of the motor and impeller should be checked to assure that they are consistent with each other.
- 5). A flexible connector should be used between the ventilator outlet flange and its mating pipe. The bolts used to fasten the outlet flange to the pipe should not be over-tightened.
- 6). Following the installation, the impeller should be turned by hand or with the use of a wrench to make sure that it turns freely. Once this is verified, the ventilator can be operated normally.
- 7). The rated motor power as calculated herein is not sufficient to drive the ventilator with an unrestricted discharge flow path. Operating the ventilator with an unrestricted discharge flow path will result in flow rates that exceed the ventilator flow rate capabilities, and such operation will quickly burn out the motor. So care must be taken in operating the ventilators to make sure that the maximum rated flows, as provided on the performance charts in this brochure, are not exceeded.
- 8). This fan is restricted for use in areas where air substances are non-corrosive and non-toxic non-alkaline or where dust particles < 150mg/m³, -20°C < temperature < 85°C. If special condition during transportation, load and unload, it is strictly prohibited to shock the ventilators.

示例图例

Example Of Curve Reading

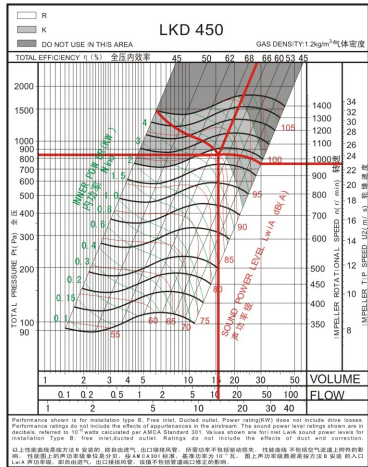

风量 Volume V=15700m³/h
 全压 Total Pressure Pt=839Pa
 动压 Dynamic Pressure Pd=109Pa
 出口速度 Outlet Velocity C=13.5 m/s
 转速 Speed n=980 r/min
 轮缘速度 Impeller Tip Speed U₂=23.2 m/s
 内功率 Inner Power Nino=5.34 kW
 声功率级 Sound Power Level Lwi A=86dB(A)
 全压内效率 Total Pressure Efficiency η_t=68.5%

出口法兰

Outlet Flange

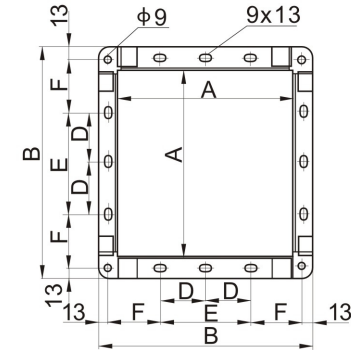
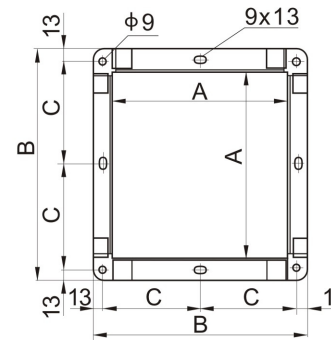

Centrifugal Ventilators With forward blade

Module Dim	200	225	250	280	315	355	400	450	500	560	630	710	800	900	1000
A	256	288	322	361	404	453	507	569	638	715	801	898	1007	1130	1267
B	296	328	362	417	460	509	563	625	694	771	857	954	1063	1186	1323
C	138	154	171	195.5	217	241.5	-	-	-	-	-	-	-	-	-
D												200	250	300	350
E							200	250	250	300	400	500	600	700	
F							168.5	199.5	209	247.5	265.5	264	268.5	280	298.5

注：表格中尺寸的单位为mm
 Note: the size unit in the form is mm

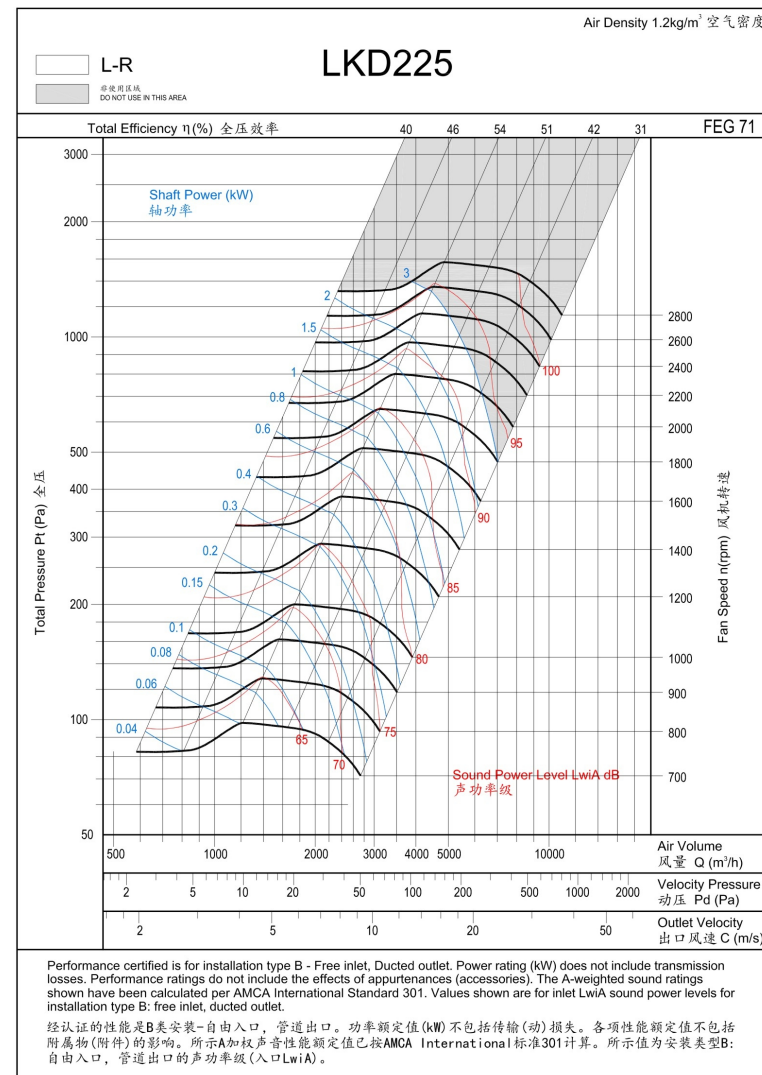
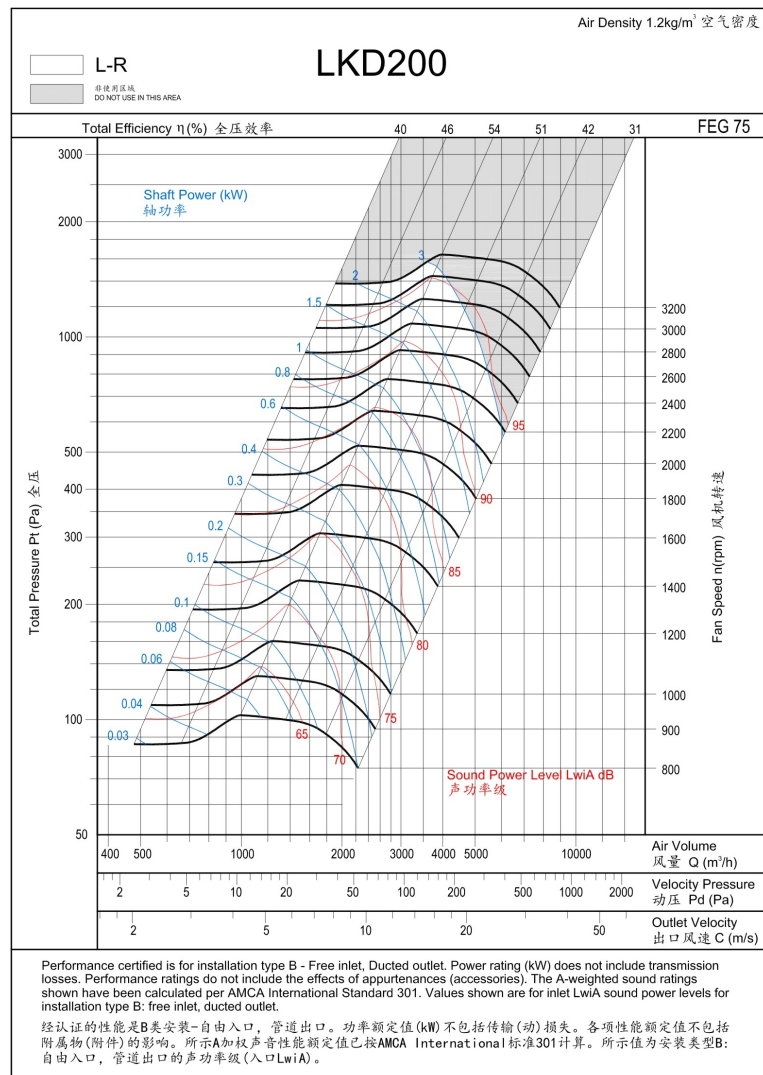

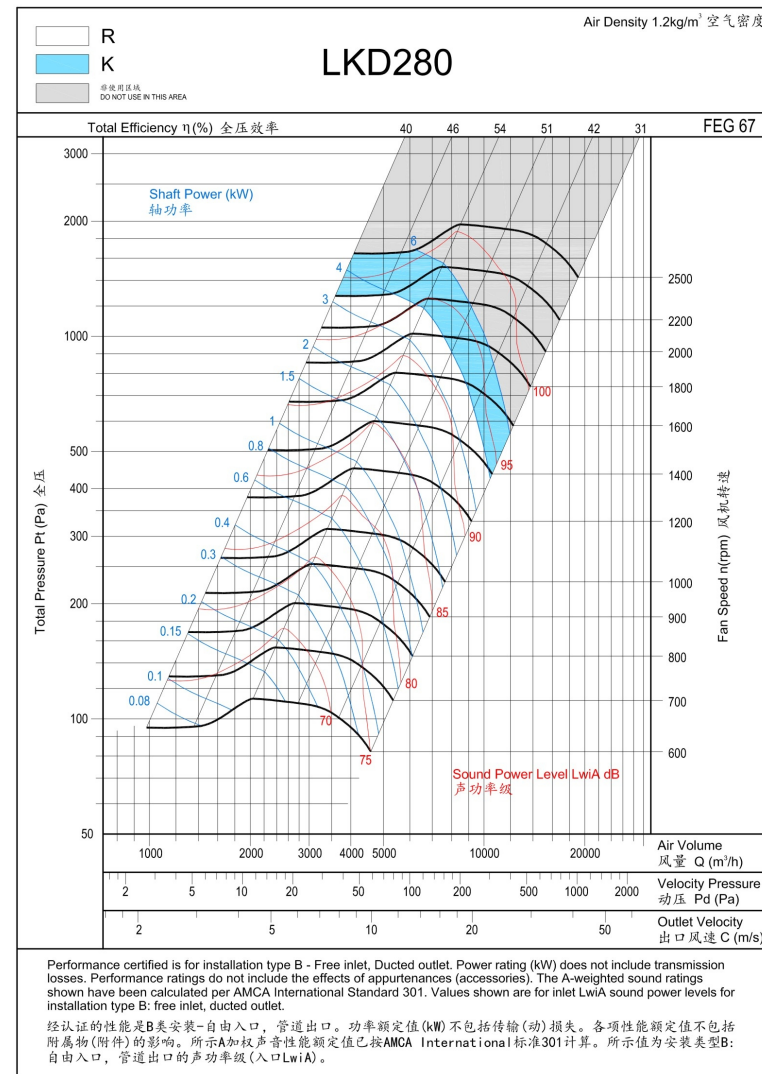
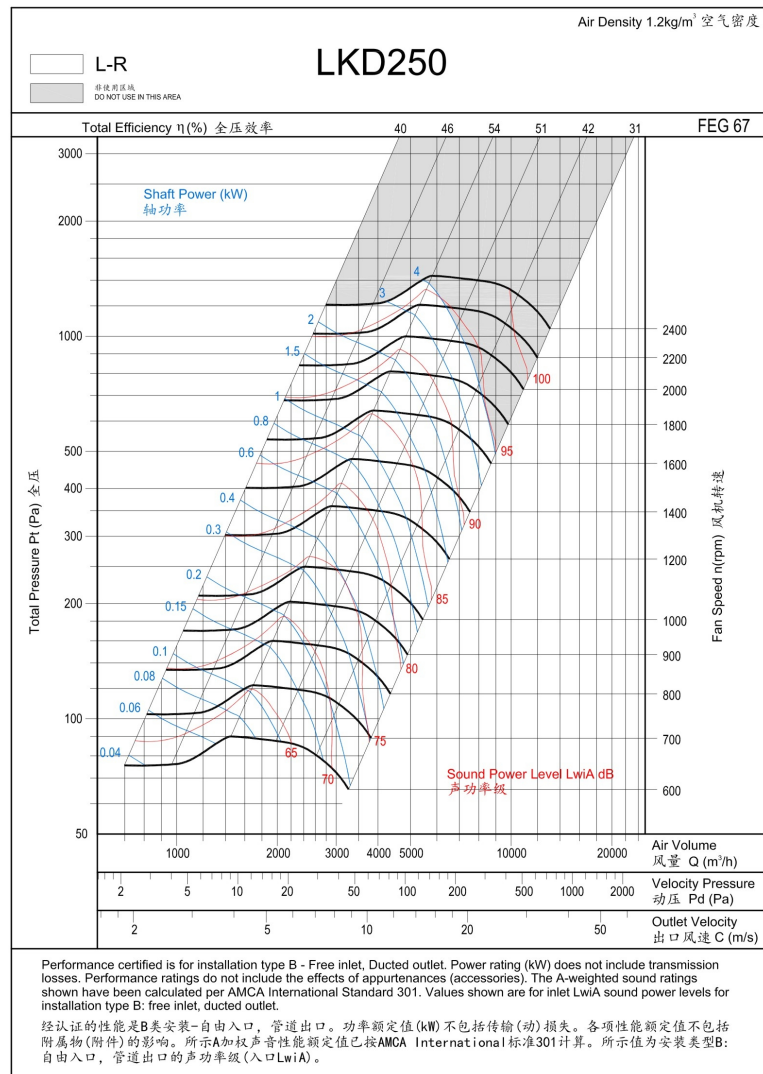

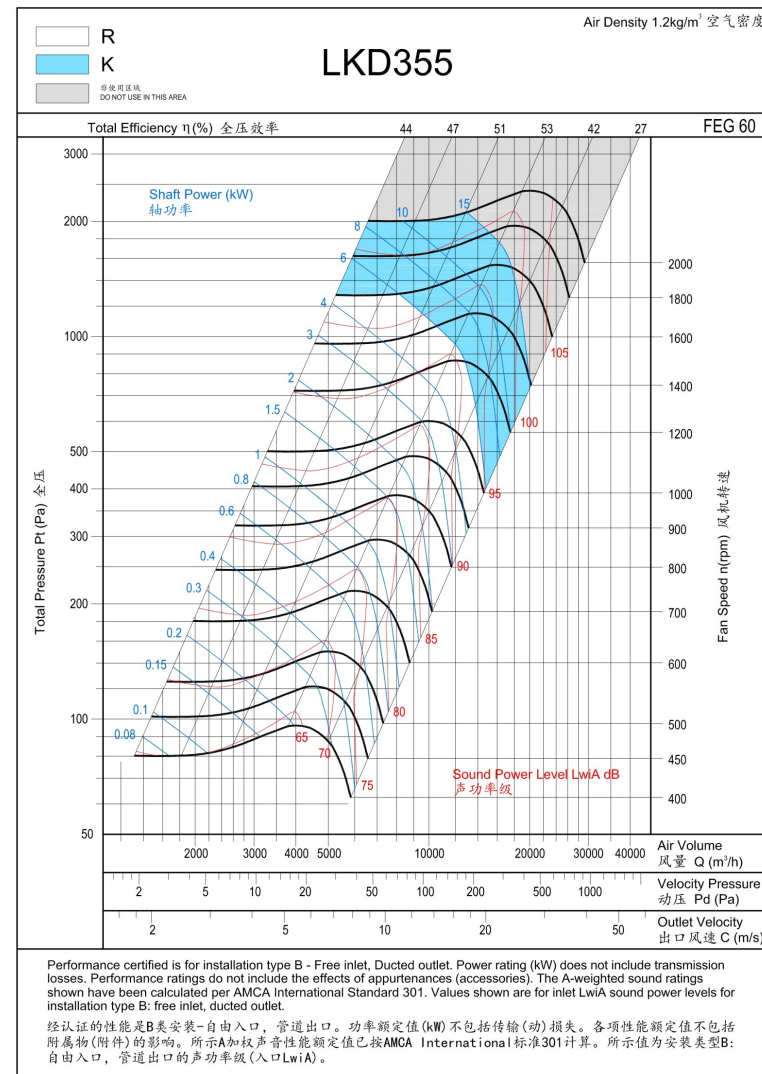
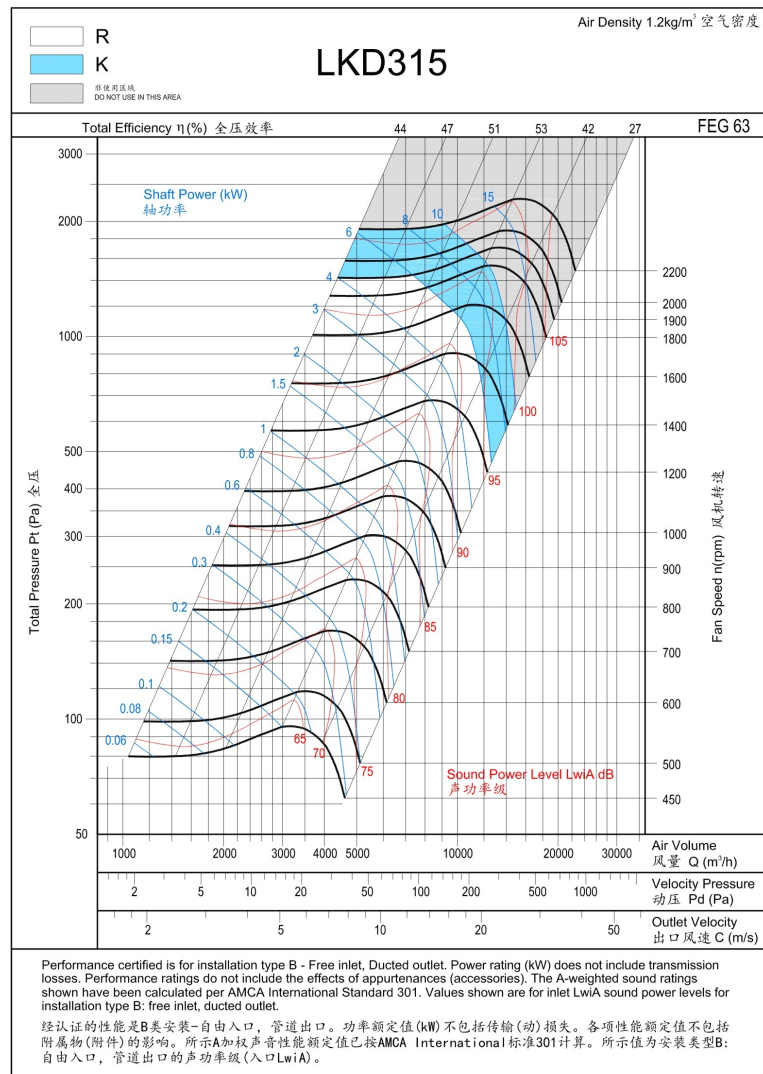

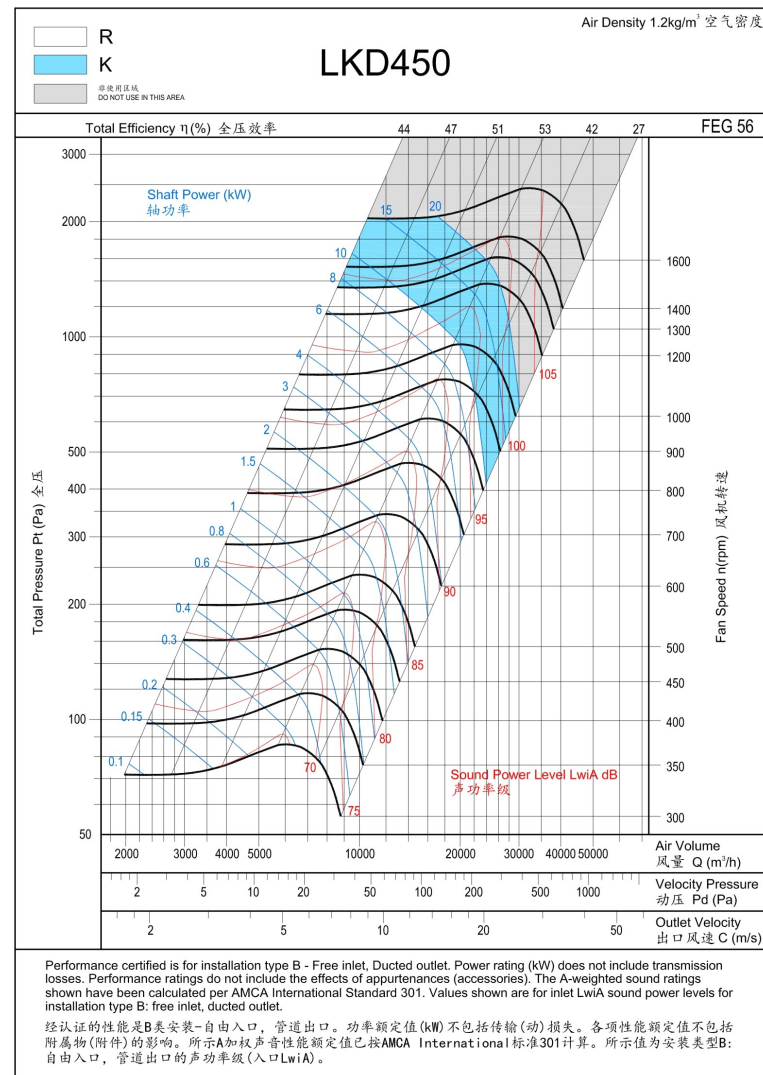
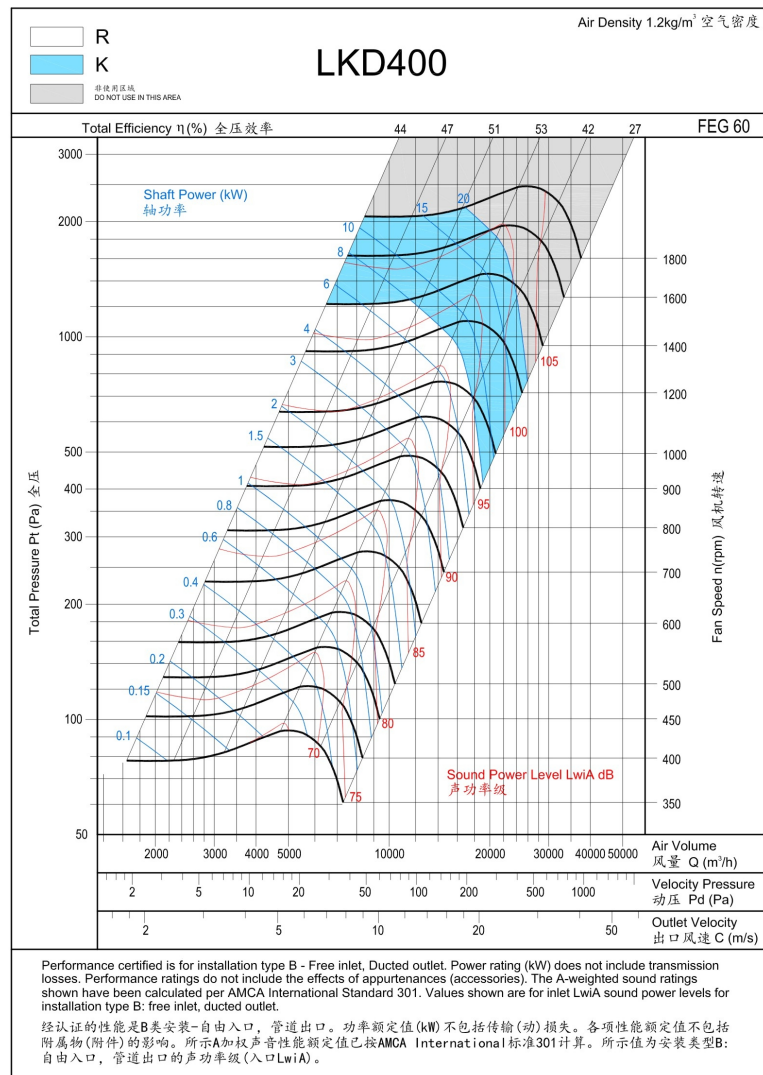

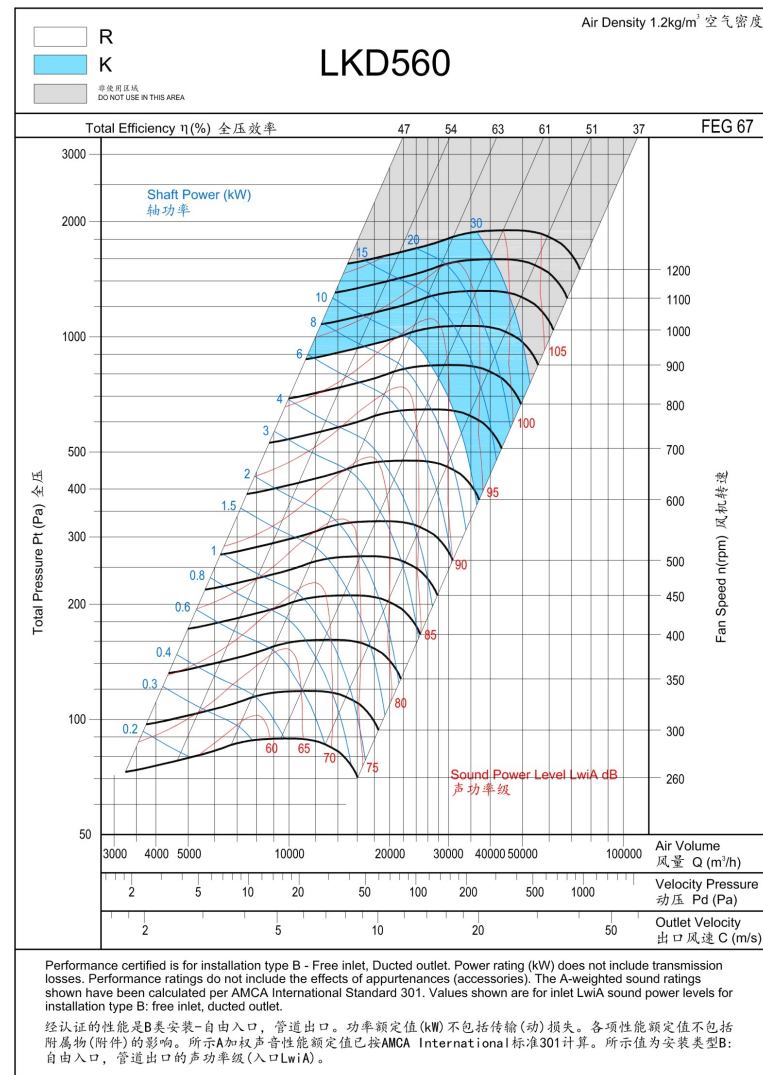
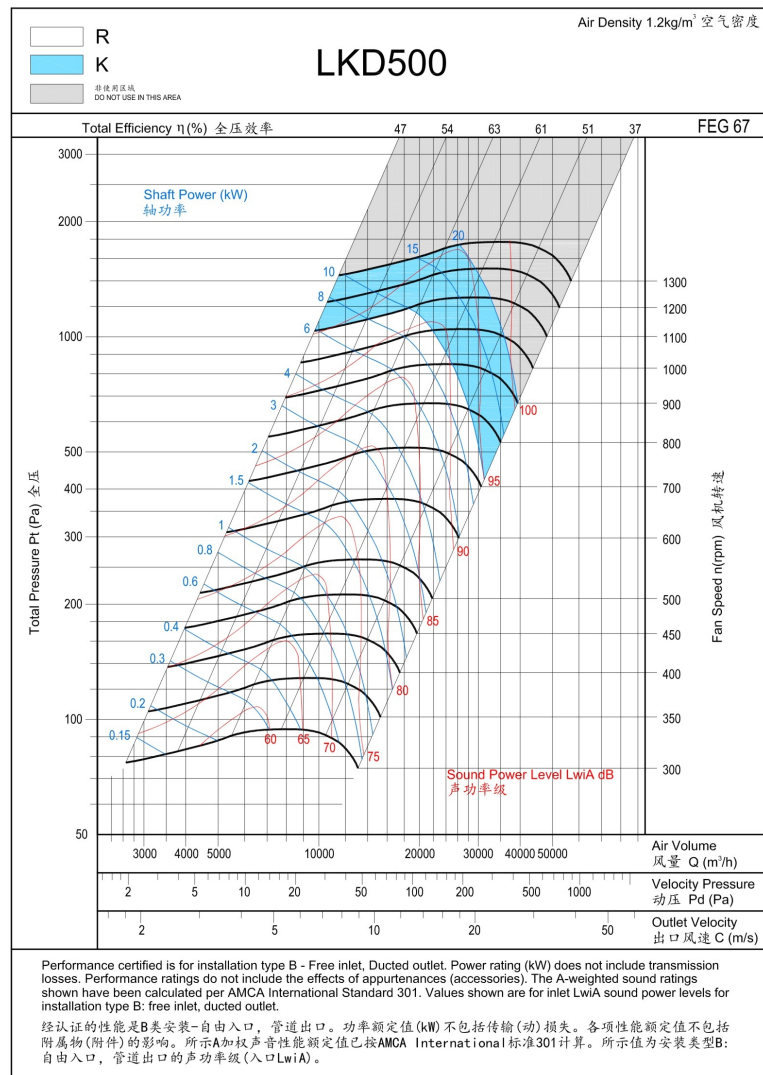

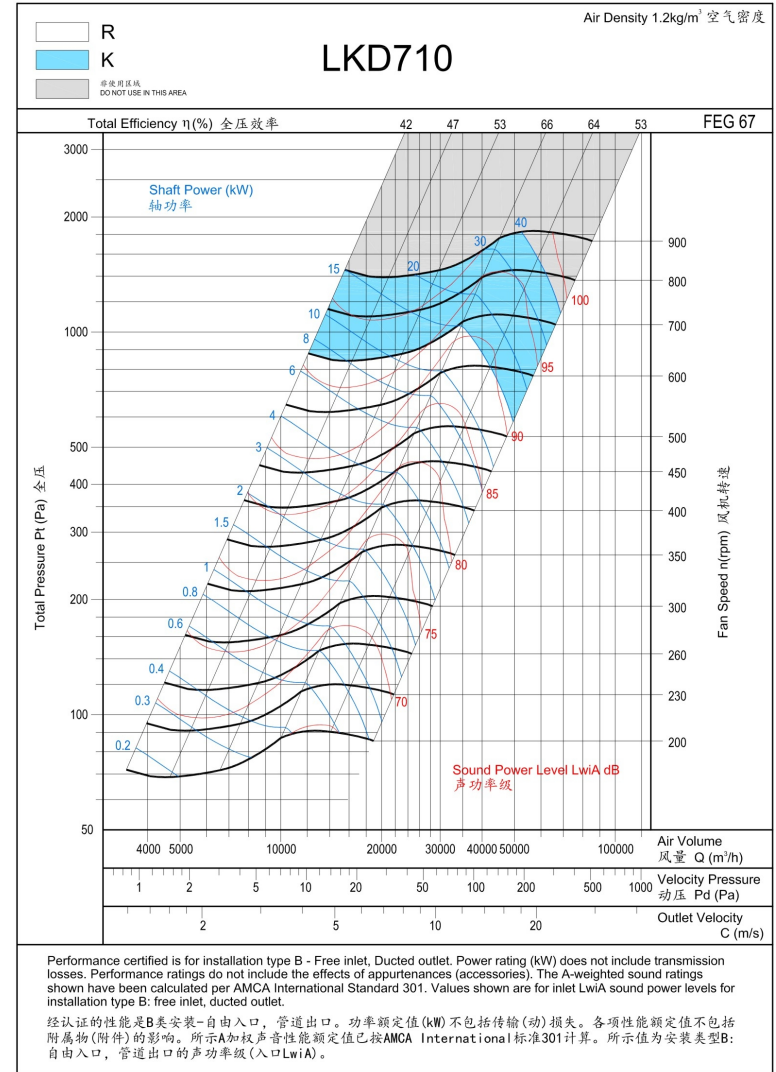
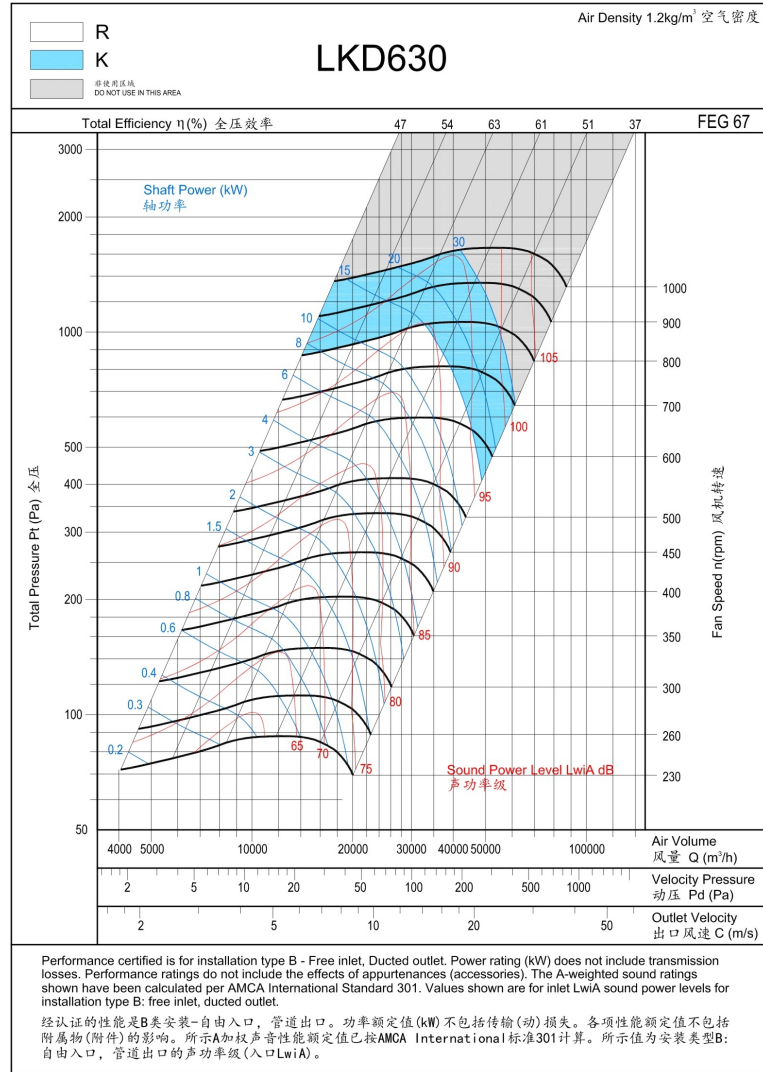

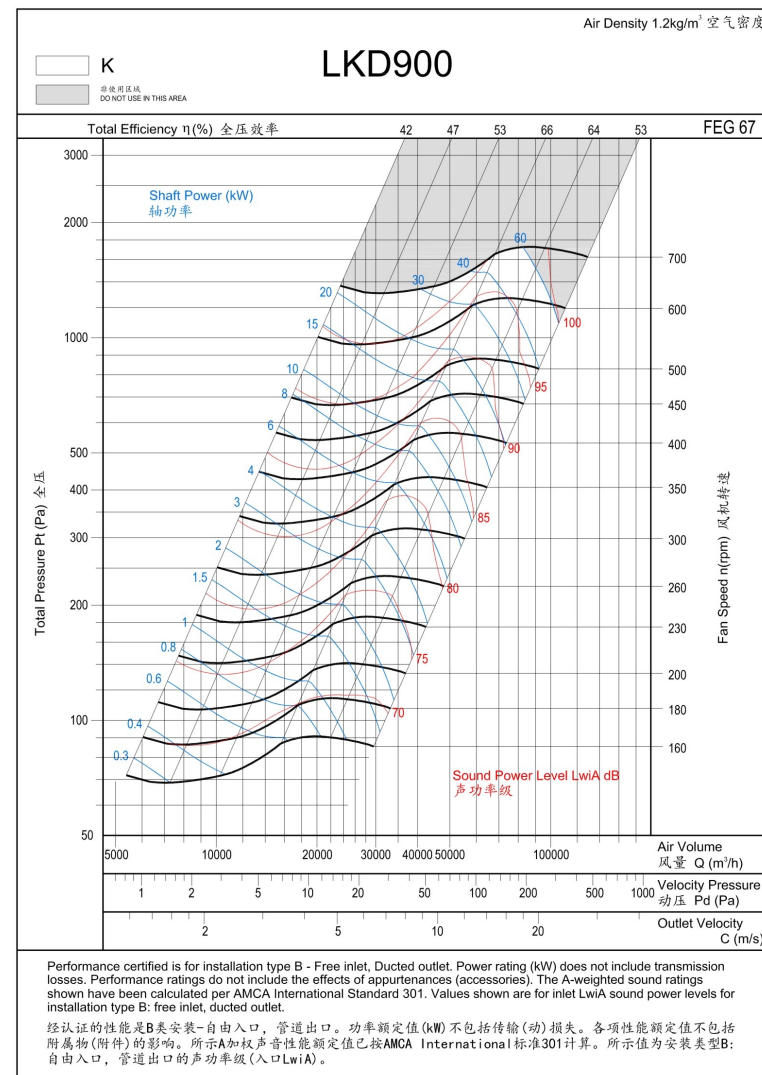
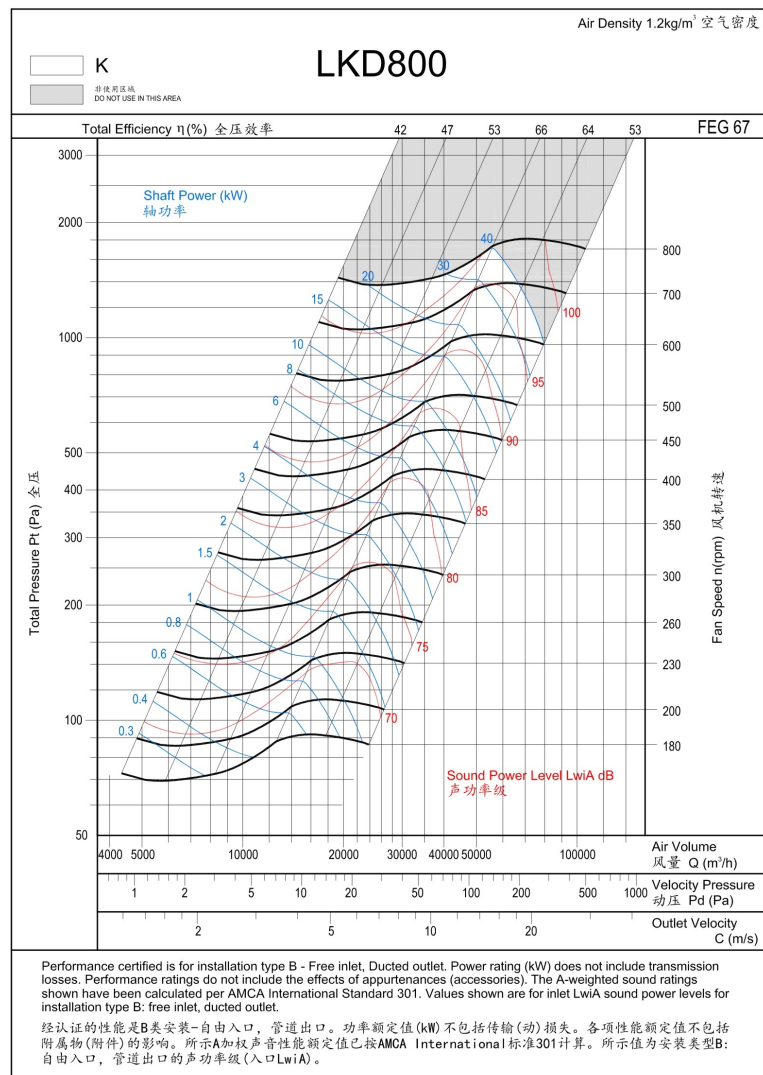

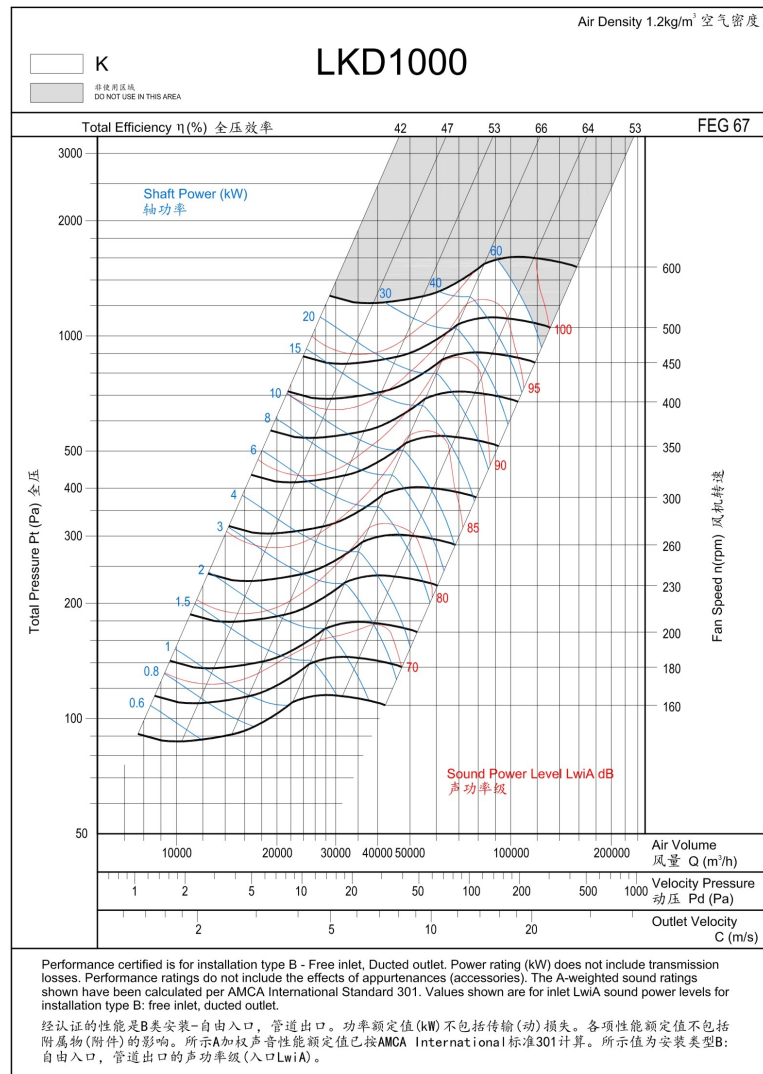

LKD-L

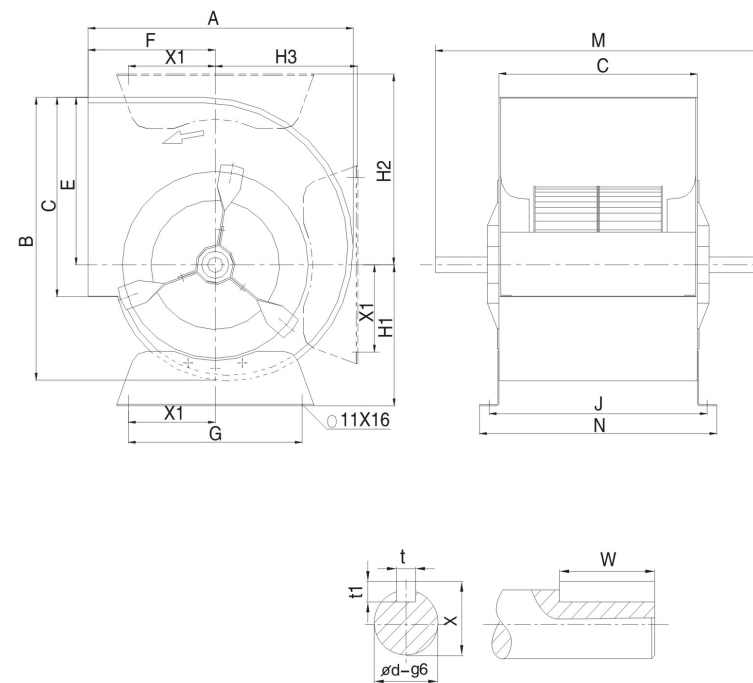

Model	A	B	C	E	F	G	J	M	N	X1	H1	H2	H3	t	t1	X	W	ϕd
200	342	364	256	215	164	224	281	420	306	112	181	245	184	6	6	22.5	40	20
225	380	407.8	288	243	180	224	313	460	338	112	197	274	204	6	6	22.5	50	20
250	417	454	322	270	195	224	347	490	372	112	210	299	227	6	6	22.5	50	20

注：表格中尺寸的单位为mm
Note: the size unit in the form is mm



LKD-R

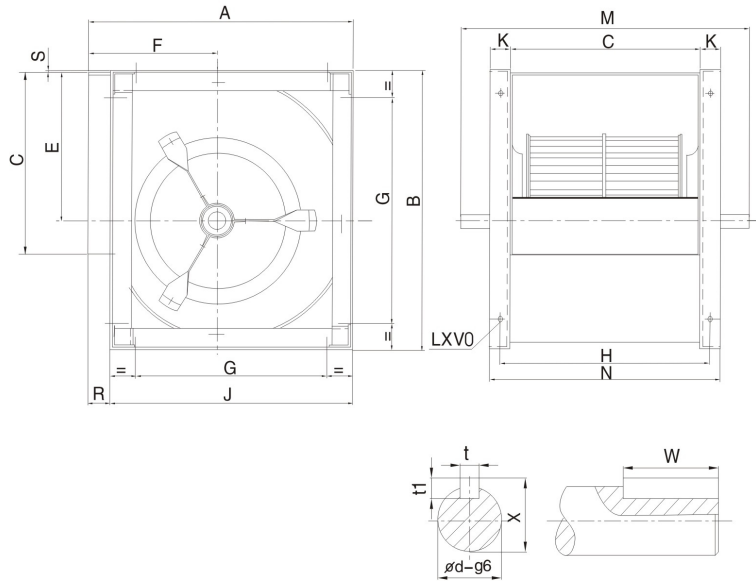

Model	A	B	C	E	F	G	H	J	K	M	N	R	S	t	t1	W	X	φd	LxV
200	343	370	256	215	164	224	281	306	25	420	306	37	4	6	6	40	22.5	20	11x16
225	383	415	288	243	180	224	313	348	25	460	338	35	3	6	6	50	22.5	20	11x16
250	419	461	322	270	195	224	347	384	25	490	372	35	4	6	6	50	22.5	20	11x16
280	466	518	361	302	215	280	391	432	30	555	421	34	5	8	7	40	28	25	13x18
315	518	578	404	340	236	280	434	480	30	600	464	38	3	8	7	40	28	25	13x18
355	578	655	453	383	261	355	493	548	40	675	533	30	6	8	7	65	33	30	13x18
400	651	736	507	431.5	290	355	547	613	40	725	587	38	4.5	8	7	65	33	30	13x18
450	726	827	569	486	322	530	609	681	40	815	649	45	5	10	8	70	38	35	13x18
500	800	914	638	538	352	530	678	750	40	885	718	50	5	10	8	50	38	35	13x18
560	893	1030	715	602	390	530	765	845	50	1000	815	48	8	12	8	70	43	40	13x18
630	999	1157	801	678.5	434	530	851	946	50	1155	901	53	7	14	9	90	53.5	50	13x18
710	1121	1303	898	765	485	630	948	1058	50	1290	998	63	7	18	11	90	64	60	17x22
800	1250	1468	1007	862	535	710	1057	1181	50	1450	1107	69	7	18	11	90	64	60	17x22
900	1408	1648	1130	971	604	800	1180	1319	60	1570	1250	89	9	18	11	100	64	60	17x22
1000	1541	1810	1267	1066	657	900	1317	1462	60	1700	1387	79	9	18	11	100	64	60	17x22

注：表格中尺寸的单位为mm
Note: the size unit in the form is mm



LKD-K

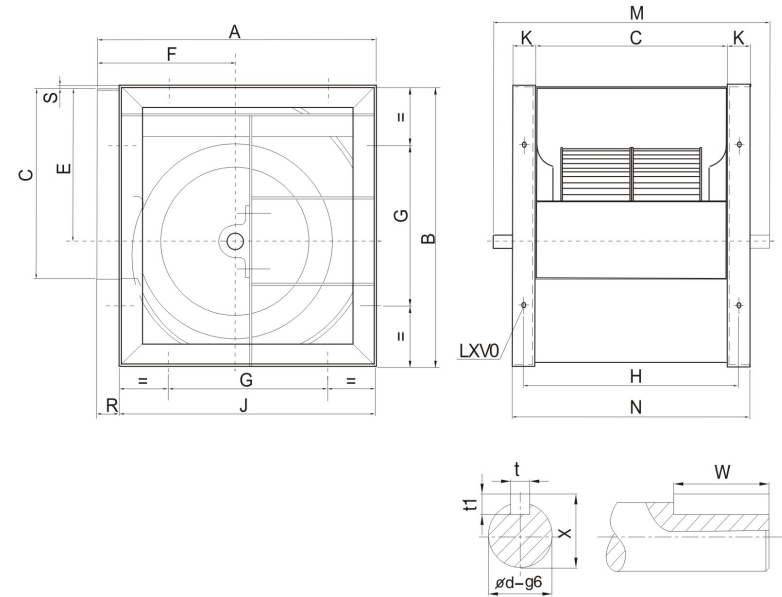

Model	A	B	C	E	F	G	H	J	K	M	N	R	S	t	t1	W	X	φd	LxV
280	466	518	361	302	215	280	391	432	30	580	421	34	5	8	7	40	33	30	13x18
315	518	578	404	340	236	280	434	480	30	625	464	38	3	8	7	40	33	30	13x18
355	578	655	453	383	261	355	493	548	40	685	533	30	6	10	8	50	38	35	13x18
400	651	736	507	431.5	290	355	547	613	40	790	587	38	4.5	10	8	70	38	35	13x18
450	726	827	569	486	322	530	609	681	40	850	649	45	5	12	8	70	43	40	13x18
500	800	918	638	538	352	530	678	750	40	920	718	50	5	12	8	70	43	40	13x18
560	893	1030	715	602	390	530	765	845	50	1070	815	48	8	14	9	90	53.5	50	13x18
630	999	1157	801	678.5	434	530	851	946	50	1155	901	53	7	14	9	90	53.5	50	13x18
710	1121	1303	898	765	485	630	948	1058	50	1290	998	63	7	18	11	90	64	60	17x22
800	1250	1468	1007	862	535	710	1057	1181	50	1450	1107	69	7	18	11	90	64	60	17x22
900	1408	1648	1130	971	604	800	1180	1319	60	1570	1250	89	9	18	11	100	64	60	17x22
1000	1541	1810	1267	1066	657	900	1317	1462	60	1700	1387	79	9	18	11	100	64	60	17x22

注：表格中尺寸的单位为mm
Note: the size unit in the form is mm



LKD-R2

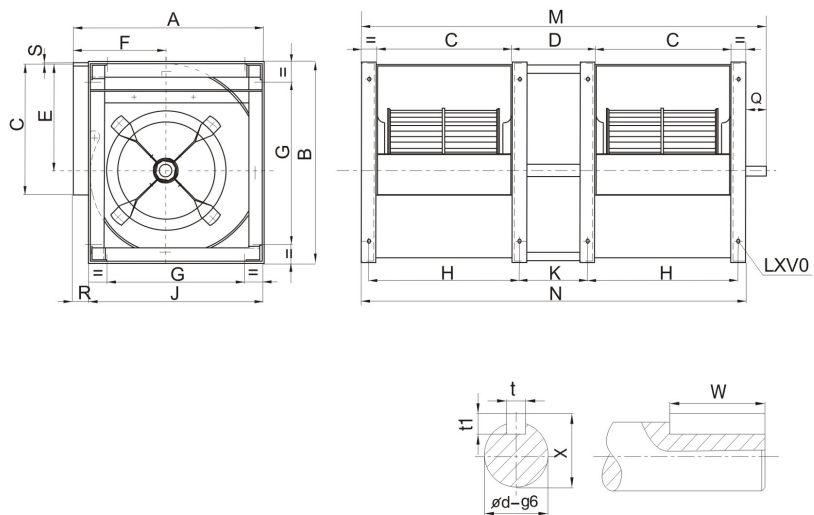

Model	A	B	C	D	E	F	G	H	J	K	M	N	Q	R	S	t	t1	W	X	φd	LxV
280	466	518	361	280	302	215	280	391	432	250	1140	1062	78	34	5	8	7	60	33	30	13x18
315	518	578	404	315	340	236	280	434	480	285	1263	1183	80	38	3	8	7	60	33	30	13x18
355	578	655	453	355	383	261	355	493	548	315	1431	1341	90	30	6	10	8	50	38	35	13x18
400	650	736	507	400	432	290	355	547	612	360	1582	1494	98	38	4	10	8	50	38	35	13x18
450	726	827	569	450	486	322	530	609	681	410	1768	1668	100	45	5	12	8	70	43	40	13x18
500	800	918	638	500	538	352	530	678	750	460	1956	1856	100	50	5	12	8	70	43	40	13x18

注：表格中尺寸的单位为mm
Note: the size unit in the form is mm



LKD-K2

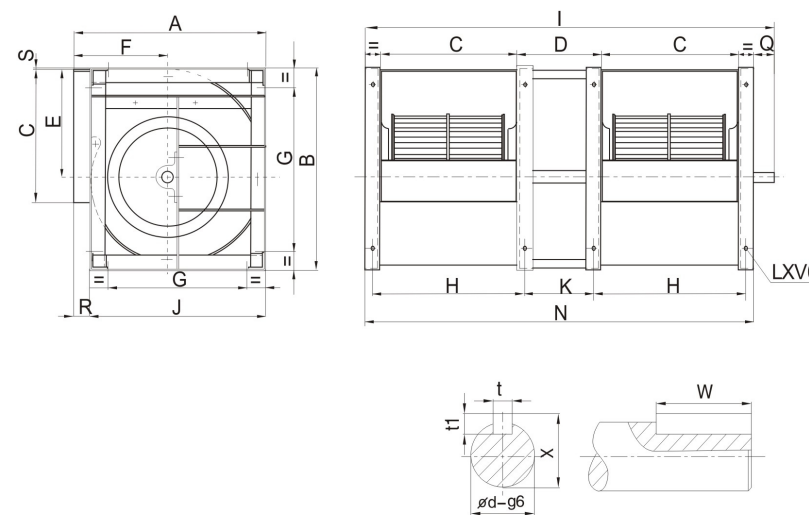

Model	A	B	C	D	E	F	G	H	I	J	K	N	Q	R	S	t	t1	φd	W	X	LxV
355	578	655	453	355	383	261	355	493	1451	548	315	1341	110	30	6	12	8	40	70	43	13x18
400	651	736	507	400	431.5	290	355	547	1604	613	360	1494	110	38	4.5	12	8	40	70	43	13x18
450	726	827	569	450	486	322	530	609	1803	681	410	1668	135	45	5	14	9	45	90	48.5	13x18
500	800	918	638	500	538	352	530	678	1991	750	460	1856	135	50	5	14	9	50	90	53.5	13x18

注：表格中尺寸的单位为mm
Note: the size unit in the form is mm



		0°				90°				180°			
左旋 LG													
右旋 RD													
型号 Model	电机 机座型号 Motor Frame Size	A	B	C	D	A	B	C	D	A	B	C	D
630	90	1340	1090	1220	1157	1340	1090	1062	1157	1340	1090	1220	1157
	100	1380	1090	1220	1157	1380	1090	1062	1157	1380	1090	1220	1157
	112	1400	1090	1220	1157	1400	1090	1062	1157	1400	1090	1220	1157
	132	1480	1090	1220	1157	1480	1090	1062	1157	1480	1090	1220	1157
	160	1620	1090	1220	1157	1620	1090	1062	1157	1620	1090	1220	1157
710	100	1480	1255	1383	1303	1480	1255	1508	1303	1480	1255	1383	1303
	112	1500	1255	1383	1303	1500	1255	1508	1303	1500	1255	1383	1303
	132	1600	1255	1383	1303	1600	1255	1508	1303	1600	1255	1383	1303
	160	1730	1255	1383	1303	1730	1255	1508	1303	1730	1255	1383	1303
	180	1800	1255	1383	1303	1800	1255	1508	1303	1800	1255	1383	1303

		0°				90°				180°			
左旋 LG													
右旋 RD													
型号 Model	电机 机座型号 Motor Frame Size	A	B	C	D	A	B	C	D	A	B	C	D
280	100	870	600	568	612	870	600	516	612	870	600	568	612
	112	890	600	568	612	890	600	516	612	890	600	568	612
	132	990	600	568	612	990	600	516	612	990	600	568	612
315	100	910	665	628	617	910	665	568	617	910	665	628	617
	112	930	665	628	617	930	665	568	617	930	665	628	617
	132	1030	665	628	617	1030	665	568	617	1030	665	628	617
355	160	1190	665	628	617	1070	665	568	617	1070	665	628	617
	100	970	725	705	655	970	725	628	655	970	725	705	655
	112	990	725	705	655	990	725	628	655	990	725	705	655
400	132	1090	725	705	655	1090	725	628	655	1090	725	705	655
	160	1250	725	705	655	1130	725	628	655	1130	725	705	655
	112	1070	790	786	736	1070	790	613	736	1070	790	786	736
	132	1170	790	786	736	1170	790	613	736	1170	790	786	736
	160	1300	790	786	736	1300	790	613	736	1300	790	786	736

注：表格中尺寸的单位为mm
Note: the size unit in the form is mm

LKD-K

		0°				90°				180°			
左旋 LG													
右旋 RD													
型号 Model	电机 机座型号 Motor Frame Size	A	B	C	D	A	B	C	D	A	B	C	D
450	112	1120	850	877	827	1120	850	776	827	1120	850	877	827
	132	1220	850	877	827	1220	850	776	827	1220	850	877	827
	160	1300	850	877	827	1300	850	776	827	1300	850	877	827
500	180	1380	850	877	827	1380	850	776	827	1380	850	877	827
	112	1190	920	981	918	1190	920	863	918	1190	920	981	918
	132	1290	920	981	918	1290	920	863	918	1290	920	981	918
560	160	1430	920	981	918	1430	920	863	918	1430	920	981	918
	180	1500	920	981	918	1500	920	863	918	1500	920	981	918
	132	1400	1070	1093	1030	1400	1070	956	1030	1400	1070	1093	1030
630	160	1550	1070	1093	1030	1550	1070	956	1030	1550	1070	1093	1030
	180	1600	1070	1093	1030	1600	1070	956	1030	1600	1070	1093	1030
	200	1660	1070	1093	1030	1660	1070	956	1030	1660	1070	1093	1030
710	132	1480	1155	1220	1157	1480	1155	1062	1157	1480	1155	1220	1157
	160	1620	1155	1220	1157	1620	1155	1062	1157	1620	1155	1220	1157
	180	1680	1155	1220	1157	1680	1155	1062	1157	1680	1155	1220	1157
800	200	1740	1155	1220	1157	1740	1155	1062	1157	1740	1155	1220	1157
	132	1600	1290	1383	1303	1600	1290	1508	1303	1600	1290	1383	1303
	160	1730	1290	1383	1303	1730	1290	1508	1303	1730	1290	1383	1303
900	180	1800	1290	1383	1303	1800	1290	1508	1303	1800	1290	1383	1303
	200	1850	1290	1383	1303	1850	1290	1508	1303	1850	1290	1383	1303
	225	1920	1290	1383	1303	1920	1290	1508	1303	1920	1290	1383	1303
1000	132	1720	1450	1548	1468	1720	1450	1330	1468	1720	1450	1548	1468
	160	1880	1450	1548	1468	1880	1450	1330	1468	1880	1450	1548	1468
	180	1950	1450	1548	1468	1950	1450	1330	1468	1950	1450	1548	1468
1000	200	2000	1450	1548	1468	2000	1450	1330	1468	2000	1450	1548	1468
	225	2050	1450	1548	1468	2050	1450	1330	1468	2050	1450	1548	1468
	160	1980	1570	1748	1648	1980	1570	1748	1648	1980	1570	1748	1648
1000	180	2030	1570	1748	1648	2030	1570	1748	1648	2030	1570	1748	1648
	200	2100	1570	1748	1648	2100	1570	1748	1648	2100	1570	1748	1648
	225	2170	1570	1748	1648	2170	1570	1748	1648	2170	1570	1748	1648
1000	160	2110	1700	1910	1810	2110	1700	1641	1810	2110	1700	1910	1810
	180	2160	1700	1910	1810	2160	1700	1641	1810	2160	1700	1910	1810
	200	2230	1700	1910	1810	2230	1700	1641	1810	2230	1700	1910	1810
1000	225	2300	1700	1910	1810	2300	1700	1641	1810	2300	1700	1910	1810
	250	2390	1700	1910	1810	2390	1700	1641	1810	2390	1700	1910	1810

注：表格中尺寸的单位为mm
Note: the size unit in the form is mm



LKD系列风机运行极限
LKD Series Ventilator Operational Limits

			200	225	250	280	315	355	400	450	500	560	630	710	800	900	1000
极限吸收功率 Max. absorbed Power	L	Kw	3	3	4	/	/	/	/	/	/	/	/	/	/	/	/
	R	Kw	3	3	4	4	6	6	8	10	10	10	15	15	/	/	/
	K	Kw	/	/	/	6	10	15	20	20	20	30	30	40	40	60	60
	R2	Kw	/	/	/	9	13	13	18	22	22	/	/	/	/	/	/
	K2	Kw	/	/	/	/	/	33	45	45	45	65	/	/	/	/	/
极限转速 Max.R P.M	L	rpm	3200	2800	2400	/	/	/	/	/	/	/	/	/	/	/	/
	R	rpm	3200	2800	2400	2200	1900	1600	1400	1300	1100	900	800	700	/	/	/
	K	rpm	/	/	/	2500	2200	2000	1800	1600	1300	1200	1000	900	800	700	600
	R2	rpm	/	/	/	1800	1600	1400	1200	1000	900	/	/	/	/	/	/
	K2	rpm	/	/	/	/	/	1600	1400	1200	1000	900	/	/	/	/	/
极限温度 (最低-20°C) Air Temperature Limits (Min-2020°C)	L	Max°C	85	85	85	/	/	/	/	/	/	/	/	/	/	/	/
	R	Max°C	85	85	85	85	85	85	85	85	85	85	85	85	85	85	85
	K	Max°C	/	/	/	85	85	85	85	85	85	85	85	85	85	85	85
	R2	Max°C	/	/	/	85	85	85	85	85	85	/	/	/	/	/	/
	K2	Max°C	/	/	/	/	/	85	85	85	85	/	/	/	/	/	/
风机重量 Fan Weight	L	Kg	7.4	9.2	11	/	/	/	/	/	/	/	/	/	/	/	/
	R	Kg	9.4	10.8	13	19	25	36	44	57	71.5	131	156	192	/	/	/
	K	Kg	/	/	/	29	35	42	57	72	92	160	185	240	290	365	480
	R2	Kg	/	/	/	38	50	71	87	113	142	/	/	/	/	/	/
	K2	Kg	/	/	/	/	/	85	107	136	175	328	/	/	/	/	/

风机选用准则

- 1、选用效率较高，风机较小，调节范围较大的风机，来满足系统可接受的性能，效率和质量要求。风机运行工作点，应选择风机高效点附近，以确保运行稳定，避免风机在喘振区工作。要降低噪声，必须降低风机转速，选择较大的风机。AV系统风机，风量风压应按运行时间较长的部分负荷工况选取。
- 2、过大风机选择，往往使风机运行在小风量区，风机进出口压差大，会引起运行不稳定和噪声脉动，发出较高噪声。过小风机选择，会引起风机转速提高，空气在离开叶片时有较高速度，也会产生较高噪声。通常风机出口平均速度在10-15 M/S
- 3、前向多翼风机：具有转速低、结构轻、低噪、调速性能好和价格便宜等特点，当设计风量和压力较小，或大流量低压力时应优先选用前向风机。
后向风机：具有效率高，噪声低，压力高和结构强等特点，当设计风机压力较大时应优先选用后向风机。
无蜗壳风机：当管网需要灵活出口位置，需要降低管道出口噪声，或管网在将来可能要变化的场合时应优先选用。
- 4、全压曲线平坦，坡度小，静压对风量功率影响大，性能区间宽的风机，适用于系统风量对静压变化敏感，需VAV风量调节的空调机组。全压曲线陡峭，坡度大，静压对风量功率影响小的风机，适用于风量固定的空调器，前向风机的电机也不会超载。皮带传动风机尽量选用4/6极电机。

Fan selection criteria

- 1, the selection of high efficiency, the smaller the smaller, the larger the scope of the wind turbine, to meet the system can accept the performance, efficiency and quality requirements. The fan operating point, should be selected in the vicinity of high efficiency fan, to ensure stable operation, avoid the work of the fan in the surge zone. To reduce the noise, we must reduce the speed of the wind turbine, the choice of a large fan. AV system fan, air pressure should be selected according to the operating time of a longer part of the load conditions.
- 2, the choice of a strong wind turbine, often make the wind turbine running in the small wind area, the pressure difference between the inlet and outlet of the wind turbine, will cause the operation of instability and noise pulse, higher noise. After selection of wind machine, will raise the rotation speed of the fan, air leaving the blades have higher speed, also can produce high noise. The average speed of the air blower is M/S 10-15
- 3, before to the multi blade fan: has the advantages of low speed, light structure, low noise, good speed regulation performance and cheap price, when the design flow and the pressure of small or large volume low pressure should give high priority to the use of wind turbine. After the wind machine, which has the advantages of high efficiency, low noise, high pressure and structure characteristics of strong, when the design pressure of fan is large should give high priority to the use of wind turbine. No shell fan: when the pipe network needs a flexible export position, need to reduce the pipeline outlet noise, or pipe network in the future may change the occasion should be preferred.
- 4, total pressure curve is flat, small steepness, static pressure has a great influence on the wind power, performance and wider range of fan for air volume system, the static pressure sensitive, need air conditioning VAV air conditioning units. Full pressure curve is steep, steep, static pressure of air power influence small wind machine, suitable for fixed volume of air conditioner, before the wind turbine motor is not overloaded. The belt drive fan to pole motor with 4/6.